







-  **Trinciatrici per giardini e aree verdi per trattori da 12 a 60 HP**
-  **Compact mulchers for gardens and green areas for tractors from 12 to 60 HP**
-  **Mulchgeräte für Gärten und Grünflächen für Traktoren von 12 bis 60 PS**
-  **Broyeurs pour jardins et espaces verts pour tracteurs de 12 a 60 CV**
-  **Desbrozadoras compactas para jardines y zonas verdes para tractores de 12 a 60 CV**

MINI



Trinciatrice compatta, da applicare a trattori con potenze comprese tra 12 e 30 HP. Consigliata per la trinciatura di erba su aree verdi, parchi e campi da gioco.



Broyeur postérieur compact pour tracteurs de 12 à 30 CV. Il est conseillé pour broyer l'herbe des espaces verts, parcs et terrains de jeu.



Compact rear mounted grass mulcher, for tractors from 12 to 30 HP. It is suited for mulching light grass on green areas, parks and sport courts.



Desbrozadora compacta para tractores con una potencia entre 12 y 30 CV, indicada para la trituración de hierba en parques, zonas verdes y campos deportivos.



Kompaktes Gerät für den Gartenbau für Traktoren von 12 bis 30 PS. Es eignet sich zum Mulchen von geringem Bestand auf Grünflächen, Parks und Sportplätzen.

| Mod. | | | | | | | | | | | | | |
|-----------------|-----|-----|-----|-----------|----|----|-----|-----|----|-----|-----|-----|-----|
| | cm | Min | Max | mm | n° | n° | PTO | A | B | C | min | max | |
| MINI 115 | 115 | 12 | 30 | 530 620 | 32 | 64 | 3 | 540 | 75 | 129 | 85 | 200 | 250 |
| MINI 125 | 125 | 12 | 30 | 530 720 | 34 | 68 | 3 | 540 | 75 | 139 | 85 | 205 | 260 |
| MINI 145 | 145 | 12 | 30 | 615 835 | 40 | 80 | 3 | 540 | 75 | 159 | 85 | 220 | 280 |



- Attacco fisso e reversibile, Cat. I.
- Fixed and reversible 3-point linkage, Cat. I.
- Fester und umkehrbarer Dreipunktbock, Kat. I.
- Attelage fixe et réversible à 3 points, Cat. I.
- Enganche fijo y reversible a los 3 puntos, Cat. I.



- Rullo livellatore autopulente regolabile in altezza.
- Self-cleaning and adjustable rear roller.
- Einstellbare und selbstreinigende Stützwalze.
- Rouleau palpeur auto-nettoyant, réglable en hauteur.
- Rodillo trasero autolimpiable y regulable en altura.



- Scatola ingranaggi con ruota libera.
- Gearbox with free wheel.
- Getriebe mit Freilauf.
- Boîtier avec roue libre.
- Caja de transmisión con rueda libre.

OPTIONALS

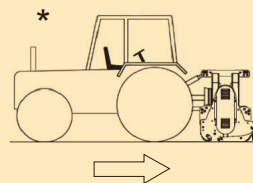

- Scatola ingranaggi con albero passante e/o doppia ruota libera*.
- Gearbox with through shaft and/or with double free wheel*.
- Getriebe mit Durchtrieb und/oder doppelter Freilauf*.
- Boîtier avec arbre de sortie et/ou double roue libre*.
- Caja de transmisión con eje cardan passante y/o doble rueda libre*.



Optional

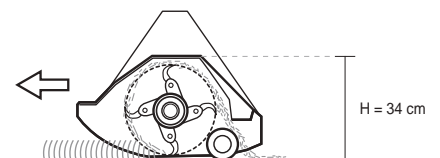

- Slitte di appoggio.
- Skids.
- Satz Kufen.
- Jeu patins.
- Patines.



- Ruote frontali stabilizzatrici in gomma, regolabili in altezza (per uso frontale).
- Front rubber wheels, height adjustable (for front/push mode).
- Regulierbare Gummistützräder für Frontanbau.
- Jeu roues frontales en caoutchouc, réglable en hauteur (version avant).
- Ruedas frontales en goma, regulables en altura (para uso frontal).





- Albero cardanico.
- Pto drive shaft.
- Gelenkwelle.
- Arbre cardan.
- Eje cardan.

GREEN





HARDOX®
WEAR PLATE









 Trinciatrice compatta reversibile, da applicare a trattori con potenze comprese tra 30 e 55 HP. Consigliata per la trinciatura di erba e ramaglia fino a Ø 2-3 cm. su aree verdi, parchi e campi da gioco.

 Broyeur réversible compact pour tracteurs de 30 à 55 CV. Il est conseillé pour broyer l'herbe et les tiges allant jusqu'à Ø 2-3 cm, des espaces verts, parcs et terrains de jeu.

 Front and rear compact mulcher to fit tractors' from 30 to 55 HP. It is suited for mulching light grass and bushes of Ø 2-3 cm on green areas, parks and sport courts.

 Desbrozadora reversible para tractores con una potencia entre 30 y 55 CV, indicada para la trituración de hierba Y ramaje hasta Ø 2-3 cm en parques, zonas verdes y campos deportivos.

 Heck und Frontanbau Gerät für den Gartenbau für Traktoren von 30 bis 55 PS. Es eignet sich zum Mulchen von Gras und Reisig bis Ø 2-3 cm auf Grünflächen, Parks und Sportplätzen.

| Mod. |  |  | |  |  |  |  |  | | |  |  |
|------------------|---|---|-----|---|---|---|--|---|-----|----|---|---|
| | cm | Min | Max | mm | n° | n° | PTO | A | B | C | min | max |
| GREEN 115 | 115 | 30 | 55 | 750 400 430 720 | 32 | 2 | 540 (1000) | 80 | 130 | 95 | 250 | 300 |
| GREEN 125 | 125 | 30 | 55 | 750 500 430 820 | 34 | 2 | 540 (1000) | 80 | 140 | 95 | 270 | 320 |
| GREEN 145 | 145 | 30 | 55 | 805 645 485 965 | 40 | 2 | 540 (1000) | 80 | 160 | 95 | 295 | 345 |
| GREEN 160 | 160 | 30 | 55 | 885 715 565 1035 | 44 | 2 | 540 (1000) | 80 | 175 | 95 | 315 | 365 |
| GREEN 180 | 180 | 30 | 55 | 885 915 565 1235 | 50 | 2 | 540 (1000) | 80 | 195 | 95 | 345 | 395 |



- Attacco spostabile meccanicamente e reversibile, su tubi cromati, Cat. I.
- Displaceable and reversible 3-point linkage, on chromate tubes, Cat. I (mechanical).
- Versetzbarer (mechanisch) und umkehrbarer Dreipunktbock, Kat. I, an verchromten Röhren.
- Attelage déportable et réversible à 3 points, avec tuyaux chromés, Cat. I (mécanique).
- Enganche desplazable y reversible a los 3 puntos sobre tubos cromados, Cat. I (desplazamiento mecánico).



- Rullo livellatore autopulente regolabile in altezza.
- Self-cleaning and adjustable rear roller.
- Einstellbare und selbstreinigende Stützwalze.
- Rouleau palpeur auto-nettoyant, réglable en hauteur.
- Rodillo trasero autolimpiable y regulable en altura.



- Scatola ingranaggi con ruota libera e albero passante.
- Gearbox with free wheel and through shaft.
- Getriebe mit Freilauf und Durchtrieb.
- Boîtier avec roue libre et arbre de sortie.
- Caja de transmisión con rueda libre y eje cardan pasante.

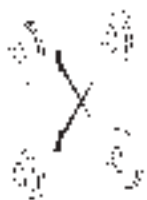

- PTO 540/1000 g/min (invertendo le pulegge).
- PTO 540/1000 rpm (reversing the pulleys).
- Getriebe 540 oder 1000 U/min (Umkehrbare Riemenscheibe).
- PDF 540/1000 t/min (en inversant les poulies).
- PTO 540/1000 g/min (invirtiendo las poleas).

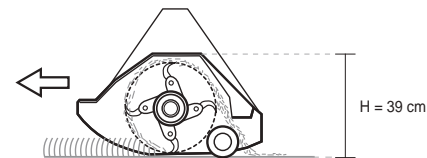
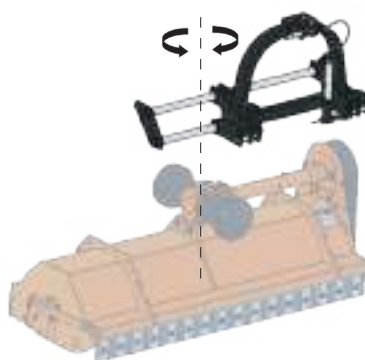

OPTIONALS



- Spostamento idraulico con tubi e innesti rapidi.
- Hydraulic side shift with hoses and quick couplings.
- Hydraulische Seitenverschiebung.
- Déport hydraulique avec tuyaux et prises rapides.
- Desplazamiento hidráulico.



- Scatola 2000 g/min. con ruota libera e albero passante (per uso frontale).
- 2000 rpm gearbox with free wheel and through shaft (for front PTO).
- Getriebe 2000 U/min mit Freilauf und Durchtrieb (Frontanbau).
- Boîtier 2000 t/min avec roue libre et arbre de sortie (pour PDF frontale).
- Caja 2000 g/min con doble rueda libre y árbol pasante (para PTO frontal).



- Doppia ruota libera e albero passante nella scatola ingranaggi*.
- Double free wheel and through shaft in the gearbox*.
- Doppelter Freilauf und Durchtrieb im Getriebe*.
- Double roue libre et arbre de sortie dans le boîtier*.
- Doble rueda libre y árbol pasante dentro de la caja engranajes*.

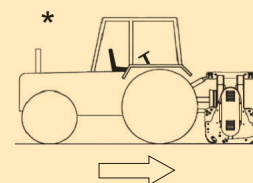

- Slitte di appoggio.
- Skids.
- Satz Kufen.
- Jeu patins.
- Patines.



- Ruote frontali stabilizzatrici in gomma, regolabili in altezza (per uso frontale).
- Front rubber wheels, height adjustable (for front/push mode).
- Regulierbare Gummistützräder für Frontanbau.
- Jeu roues frontales en caoutchouc, réglable en hauteur (version avant).
- Ruedas frontales en goma, regulables en altura (para uso frontal).





- Albero cardanico.
- Pto drive shaft.
- Gelenkwelle.
- Arbre cardan.
- Eje cardan.

PARK/P













 Trinciatrice compatta da applicare a trattori con potenze comprese tra 20 e 60 HP. Consigliata per lo sfalcio di erba cespugli e ramaglia fino a \varnothing 2-3 cm su parchi, aree verdi, campi da gioco.

 Broyeur postérieur compact pour tracteurs de 20 à 60 CV. Il est conseillé pour broyer l'herbe, les buissons et les tiges allant jusqu'à \varnothing 2-3 cm dans les parcs, les espaces verts, les terrains de jeu, etc.

 Compact rear mounted mulcher, for tractors from 20 to 60 HP. It is suited to mulch grass, bushes and light pruning of \varnothing 2-3 cm on parks, green areas, sport courts, etc.

 Desbrozadora compacta para tractores con una potencia entre 20 y 60 CV, indicada para la trituración de hierba, arbustos y restos de poda (hasta 2-3 cm. \varnothing) en parques, zonas ver-des y campos deportivos.

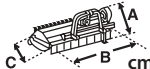
 Kompaktes Gerät für Traktoren von 20 bis 60 PS. Es eignet sich zum Mulchen von Gras und Reisig bis \varnothing 2-3 cm auf Parks, Grünfläche, Sportplätzen, etc.

| Mod. |  |  |  |  |  |  |  |  |  |  | | | |
|-------------------|---|---|---|---|---|---|--|---|---|---|---------|-----------|-----------|
| | cm | Min HP | Max HP | mm | n° | n° | n° | PTO | A cm | B cm | C cm | min KG | max KG |
| PARK/P 105 | 105 | 20 | 60 | 590 460 270 780 | 10 | 30 | 2 | 540 (1000) | 79 | 120 | 80 | 265 | 320 |
| PARK/P 115 | 115 | 20 | 60 | 590 560 270 880 | 10 | 30 | 2 | 540 (1000) | 79 | 130 | 80 | 280 | 340 |
| PARK/P 125 | 125 | 20 | 60 | 690 560 370 880 | 12 | 36 | 2 | 540 (1000) | 79 | 140 | 80 | 295 | 350 |
| PARK/P 135 | 135 | 20 | 60 | 775 575 455 895 | 12 | 36 | 2 | 540 (1000) | 79 | 150 | 80 | 310 | 360 |
| PARK/P 145 | 145 | 20 | 60 | 775 675 455 995 | 14 | 42 | 2 | 540 (1000) | 79 | 160 | 80 | 320 | 375 |
| PARK/P 160 | 160 | 20 | 60 | 875 715 555 1045 | 14 | 42 | 2 | 540 (1000) | 79 | 175 | 80 | 355 | 405 |
| PARK/P 180 | 180 | 20 | 60 | 875 915 555 1245 | 16 | 48 | 3 | 540 (1000) | 79 | 195 | 80 | 370 | 430 |



- Attacco spostabile meccanicamente, Cat. I.
- Displaceable three point linkage, Cat. I (mechanical).
- Versetzbarer Dreipunktbock, Kat. I (mechanischer).
- Attelage déportable à 3 points, Cat. I (mécanique).
- Enganche a los 3 puntos del tractor desplazable, Cat. I (desplazamiento mecánico).



- Scatola ingranaggi con ruota libera.
- Gearbox with free wheel.
- Getriebe mit Freilauf.
- Boîtier avec roue libre.
- Caja de transmisión con rueda libre.

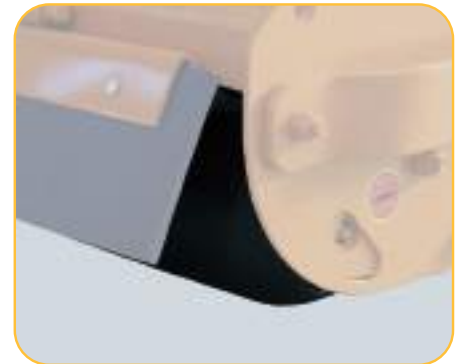

- Rullo livellatore autopulente regolabile in altezza.
- Self-cleaning and adjustable rear roller.
- Einstellbare und selbstreinigende Stützwalze.
- Rouleau palpeur auto-nettoyant, réglable en hauteur.
- Rodillo trasero autolimpiable y regulable en altura.



Optional

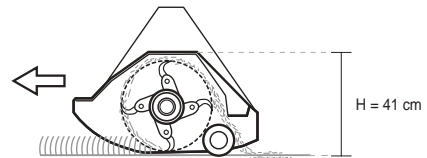

OPTIONALS



- Spostamento idraulico con tubi e innesti rapidi.
- Hydraulic side shift with hoses and quick couplings.
- Hydraulische Seitenverschiebung.
- Déport hydraulique avec tuyaux et prises rapides.
- Desplazamiento lateral de accionamiento hidráulico.



- Slitte d'appoggio.
- Skids.
- Satz Kufen.
- Jeu patins.
- Patines.



- Albero cardanico.
- Pto drive shaft.
- Gelenkwelle.
- Arbre cardan.
- Eje cardan.



bertima.it



MINI



GREEN



PARK/P

Le illustrazioni e i dati del presente catalogo sono indicative e non vincolanti per il costruttore • All pictures and data above are indicative only and not binding for the manufacturer • Alle in diesem Katalog enthaltenen Angaben und Zeichnungen sind annähernd und unverbindlich • Toutes les données insérées dans ce catalogue ont été indiquées seulement à titre de renseignement • Las fotografías y los datos mostrados son meramente indicativos y podrían ser variados sin previo aviso por el fabricante.



BERTI[®]
MACCHINE AGRICOLE



Via Musi, 1/A-3-4 - 37042 Caldiero (VR) ITALY
Tel. +39.045.6139711 - Fax +39.045.6150251
info@bertima.it



 **MADE IN ITALY**

D006.12 REV.04 - 07.09.2021